

# J.101

The ideal choice for heavy duty Spirals and J-curves. Spiral Coolers, Radius Conveyors. Construction: side modules and center modules. FDA approved.



**SCANBELT**  
...keeping industry moving...

## SUGGESTED INDUSTRIES



## STANDARD FEATURES

Belt surface	Smooth
Open area	52 %
Strength	The ideal choice for medium-duty transportation
Cleanability	Good
Width interval	Normally 20 mm. E.g: 210 mm, 230 mm etc.

## BELT DATA

Belt materials	Temperature		Rods	Max. belt pull kg/m	Belt weight kg/m <sup>2</sup>	Standard Colours
	Min.	Max.				
PP	+ 5	100	PP	Please contact ScanBelt		White/Blue
			Nylon			
			Steel			
POM	- 43	95	PP	160	7	Natural/Blue
			Nylon	250	7	
			Steel	250	12,5	

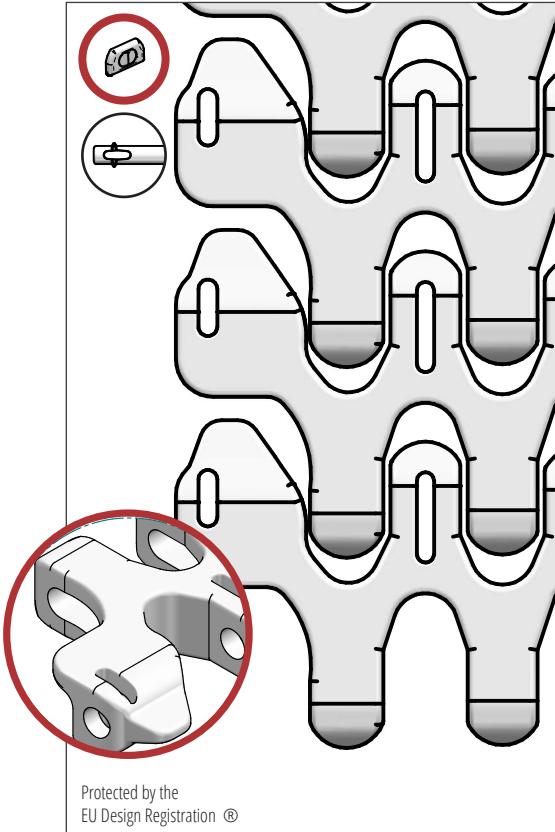

## ACCESSORIES

Type	mm
Flights	25, 50, 75
Hooks	Hooks or tabs
Friction Top	Yes

## SPROCKET ENGAGEMENT

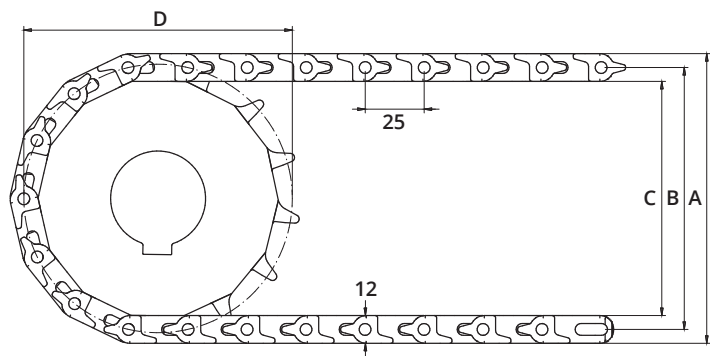
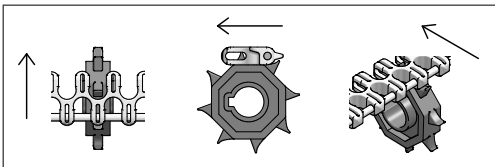

## SPROCKET DATA

A = Outside, B = Pitch, C = Inside, D = Pitch Circle Diameter

No. Teeth	A	B	C	D	Hub Width	Round Bore		Square Bore	
	mm	mm	mm	mm		mm	Inch	mm	Inch
8	74	62	54	66	20	20 / 25	¾ / 1	25	1½
12	106	96	84	98	20	20 / 25 / 30 / 40	¾ / 1 / 1¼	25 / 40	1½
20	173	161	149	162	35	25 / 30 / 40	1 / 1¼	25 / 40	1½

# J.101 BELT DIMENSIONS

J. 101 - 25 mm radius belt dimensions

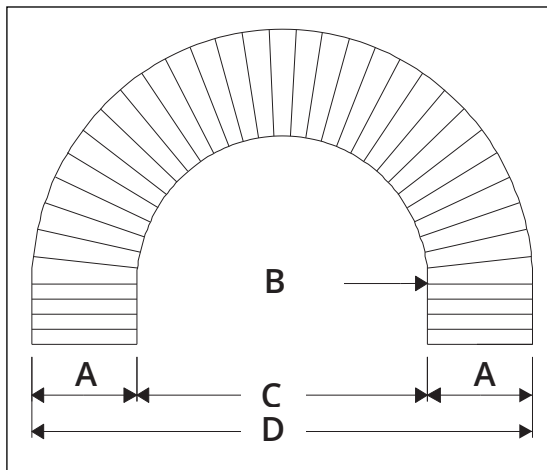

<b>A</b>	107	210	292	394	497	600	702	805	907	1011
<b>B</b>	150	300	450	650	850	1035	1250	1460	1680	1905
<b>C</b>	300	600	900	1300	1700	2070	2500	2920	3360	3810
<b>D</b>	514	1020	1484	2088	2644	3220	3854	4480	5124	5782

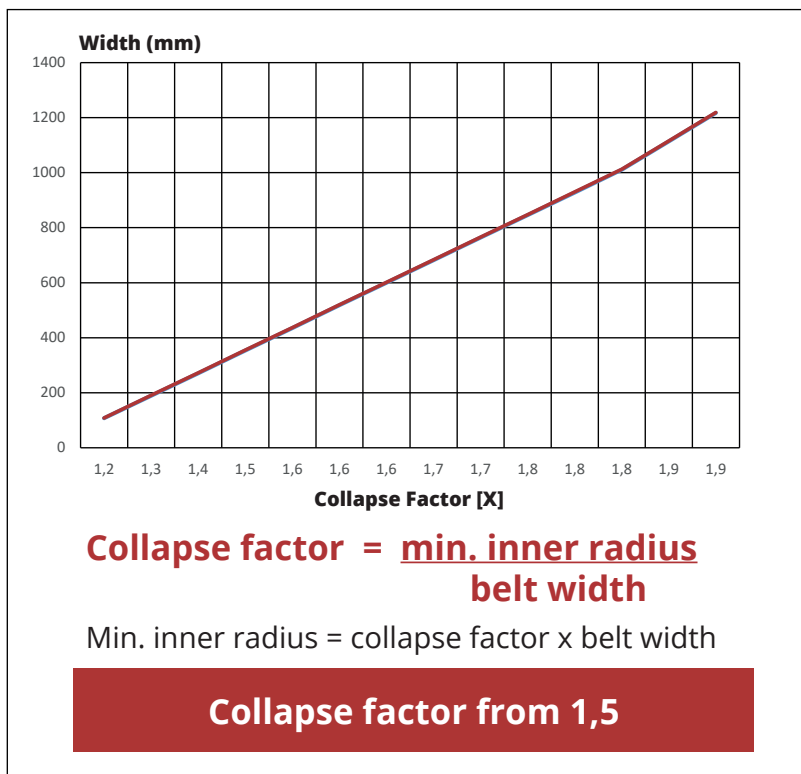

## STANDARD WIDTH

Belt width.	Min.inner radius.	Belt width.	Min.inner radius
107	150	579	1000
128	180	600	1035
148	210	620	1075
169	240	641	1115
189	270	682	1205
210	300	702	1250
230	330	723	1290
251	370	744	1330
271	410	764	1370
292	450	785	1415
312	490	805	1460
333	530	826	1505
353	570	846	1550
374	610	867	1595
394	650	887	1635
414	690	907	1680
414	690	928	1725
435	730	949	1770
455	770	970	1815
477	810	990	1860
497	850	1011	1905
518	885	1114	2425
538	920	1217	2350
559	960	1320	2595