

S.100R HOOK

Selección ideal para el transporte de peso medio en transportadores curvos y en espiral.
Esta versión integra ganchos girados al exterior en los extremos. Aprobado por FDA.

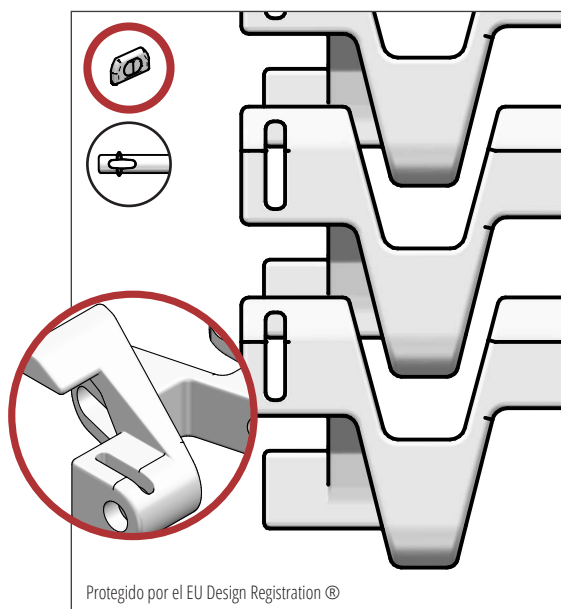

INDUSTRIAS SUGERIDAS



CARACTERÍSTICAS ESTÁNDAR

| | |
|------------------|--|
| Superficie banda | Abierta y lisa |
| Área abierta | 52 % |
| Resistencia | Selección ideal para transporte de peso medio |
| Limpieza | Buena |
| Ancho estándar | Normalmente de 20,5 mm., ejemplo de 209 mm, 229 mm, etc. |

DATOS TÉCNICOS

| Material de banda | Temperaturas | | Pasadores | Tracción máxima kg/m | Peso banda kg/m ² | Colores estándar |
|-------------------|--------------|------|-----------|----------------------|------------------------------|------------------|
| | Min. | Max. | | | | |
| PP | + 5 | 100 | PP | 60 | 4,5 | Blanco/Azul |
| | | | Nylon | 90 | 4,5 | |
| | | | Inox | 100 | 10 | |
| POM | - 43 | 95 | PP | 75 | 7 | Natural/Azul |
| | | | Nylon | 110 | 7 | |
| | | | Inox | 150 | 12,5 | |

ACCESORIOS

| Tipo | mm |
|--------------------------|------------|
| Empujadores | 25, 50, 75 |
| Pared lateral | - |
| Superficie alta fricción | Si |

GANCHOS

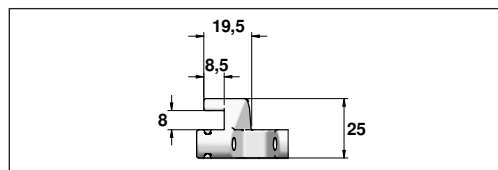

SENTIDO DE GIRO

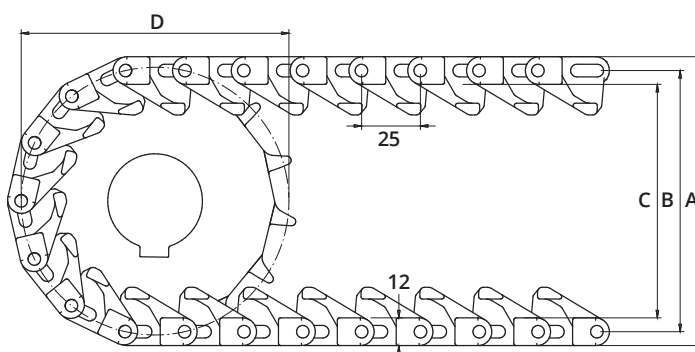
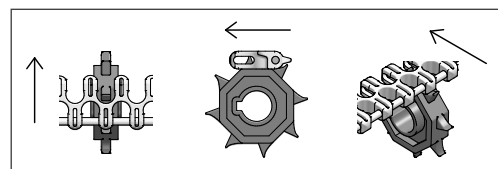

DATOS RUEDAS DENTADAS

A = Exterior, B = Primitivo, C = Interior, D = Diámetro Primitivo

| Num. de dientes | A | B | C | D | Ancho núcleo | Eje redondo | | Eje cuadrado | |
|-----------------|-----|-----|-----|-----|--------------|-------------------|------------|--------------|---------|
| | mm | mm | mm | mm | | mm | Pulgada | mm | Pulgada |
| 12 | 106 | 94 | 82 | 98 | 20 | 20 / 25 / 30 / 40 | ¾ / 1 / 1¼ | 25 / 40 | 1½ |
| 20 | 173 | 161 | 149 | 162 | 35 | 25 / 30 / 40 | 1 / 1¼ | 25 / 40 | 1½ |

S.100R Ganchos

MEDIDAS DE LA BANDA

S.100 R Ganchos - 25 mm radial

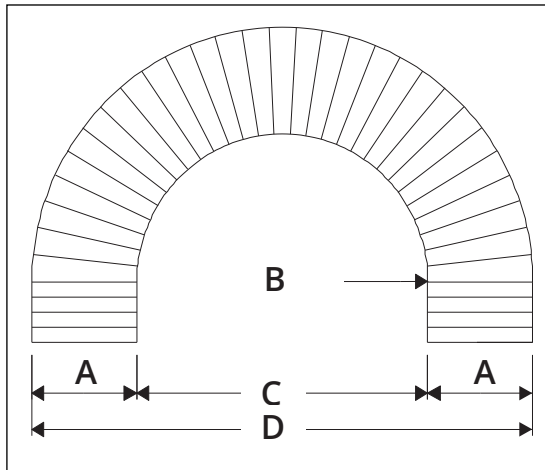

A = Ancho estándar de banda
 B = Radio interior
 C = Diámetro interior
 D = Diámetro exterior

| | | | | | | | | | | |
|---|------|------|------|------|------|------|------|------|------|------|
| A | 209 | 270 | 373 | 475 | 577 | 679 | 782 | 884 | 986 | 1088 |
| B | 297 | 419 | 617 | 810 | 1044 | 1173 | 1408 | 1675 | 1898 | 2143 |
| C | 594 | 838 | 1234 | 1620 | 2088 | 2346 | 2816 | 3350 | 3796 | 4286 |
| D | 1012 | 1378 | 1980 | 2570 | 3242 | 3704 | 4380 | 5118 | 5768 | 6462 |

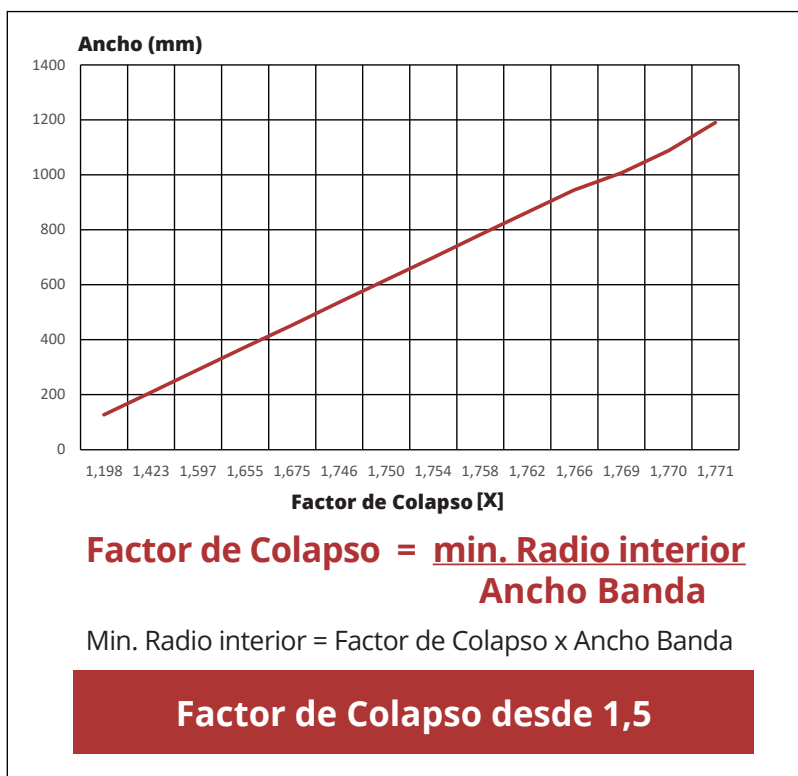

ANCHOS ESTÁNDAR

| Ancho Banda | Radio int. mínimo | Ancho Banda. | Radio int. mínimo |
|-------------|-------------------|--------------|-------------------|
| 127 | 152 | 618 | 1125 |
| 147 | 183 | 638 | 1164 |
| 168 | 220 | 659 | 1127 |
| 188 | 260 | 679 | 1173 |
| 209 | 297 | 699 | 1216 |
| 229 | 336 | 720 | 1264 |
| 250 | 378 | 741 | 1312 |
| 270 | 419 | 761 | 1358 |
| 291 | 465 | 782 | 1408 |
| 311 | 504 | 802 | 1459 |
| 332 | 543 | 823 | 1513 |
| 352 | 581 | 843 | 1564 |
| 373 | 617 | 864 | 1618 |
| 393 | 652 | 884 | 1675 |
| 413 | 688 | 904 | 1734 |
| 433 | 723 | 925 | 1753 |
| 453 | 763 | 945 | 1800 |
| 475 | 810 | 966 | 1850 |
| 495 | 856 | 986 | 1898 |
| 516 | 906 | 1007 | 1944 |
| 536 | 954 | 1088 | 2143 |
| 557 | 1000 | 1190 | 2404 |
| 577 | 1044 | | |
| 598 | 1085 | | |