

# S.201

Selección ideal para el transporte pesado en transportadores curvos y en espirales.  
El ensamblado es con módulos centrales y laterales.



**SCANBELT**  
...keeping industry moving...

## INDUSTRIAS SUGERIDAS



## CARACTERÍSTICAS ESTÁNDAR

Superficie banda	Abierta y lisa
Área abierta	47 %
Resistencia	Ideal para transporte pesado en curvas y espirales.
Limpieza	Buena
Ancho estándar	Normalmente de 20 mm, ejemplo: 210 mm, 230 mm, etc.

## DATOS TÉCNICOS

Material de banda	Temperaturas		Rods	Tracción máxima kg/m	Peso banda kg/m <sup>2</sup>	Colores estándar
	Min.	Max.				
PP	+ 5	100	PP	165	4,7	Blanco/Azul
			Nylon	230	4,7	
			Steel	230	7	
POM	- 43	95	PP	205	8	Natural/Azul
			Nylon	305	8	
			Steel	305	12	

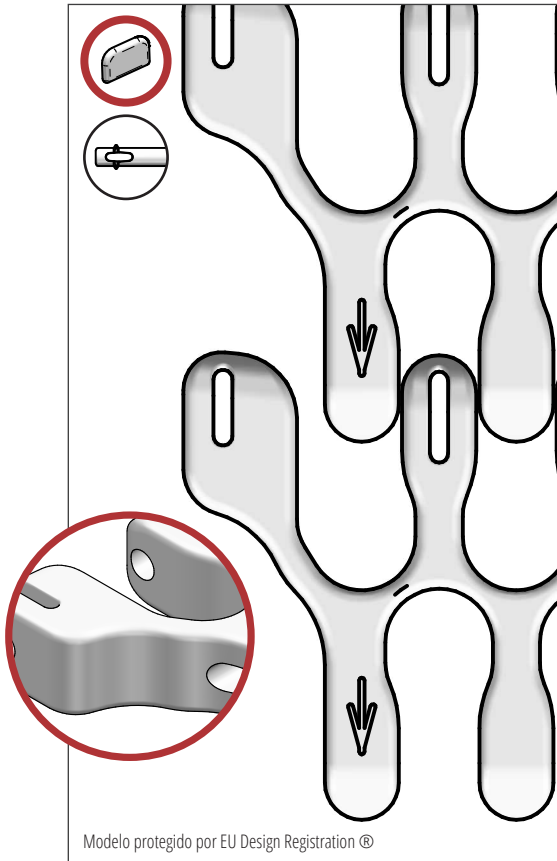

Modelo protegido por EU Design Registration ©

## ACCESORIOS

Tipo	mm
Nub top	3
Pared lateral	-
Superficie alta fricción	-
Ganchos	Si

## SENTIDO DE GIRO

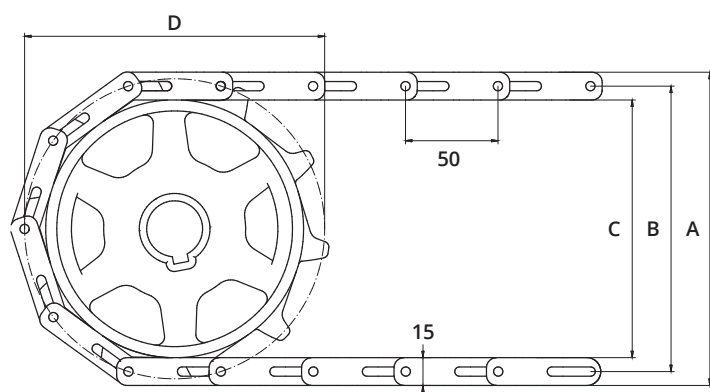
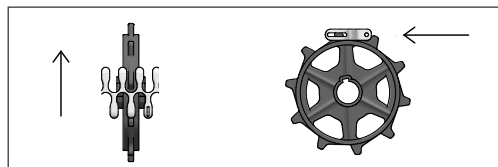

## DATOS RUEDAS DENTADAS

A = Exterior, B = Primitivo, C = Interior, D = Diámetro Primitivo

Num. de dientes	A	B	C	D	Ancho núcleo	Eje redondo		Eje cuadrado	
	mm	mm	mm	mm		mm	Pulgada	mm	Pulgada
10	169	154	139	162	35	25 / 30 / 40 / 50 / 60		25 / 40 / 60	
							1 / 1¼		1½ / 2½

# S.201

## MEDIDAS DE LA BANDA

S.201 - 50 mm Radial

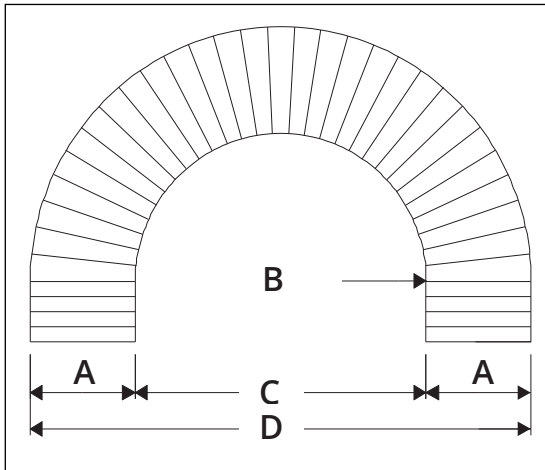

A = Ancho estándar de banda

B = Radio interior

C = Diámetro interior

D = Diámetro exterior

<b>A</b>	107	210	292	394	497	600	702	805	907	1011
<b>B</b>	140	245	374	524	678	834	993	1159	1329	1506
<b>C</b>	280	490	748	1048	1356	1668	1986	2318	2658	3012
<b>D</b>	494	910	1332	1836	2350	2868	3390	3928	4472	5034

## ANCHOS ESTÁNDAR

Ancho Banda.	Radio int. mínimo	Ancho Banda.	Radio int. mínimo
107	140	579	802
128	155	600	834
148	165	620	865
169	190	641	897
189	215	662	930
210	245	682	962
230	275	702	993
251	315	723	1027
271	343	744	1060
292	374	764	1093
312	402	785	1126
333	433	805	1159
353	462	826	1194
374	494	846	1227
394	524	867	1261
414	555	887	1295
435	587	907	1329
455	617	928	1364
477	649	949	1400
497	678	970	1436
518	710	990	1470
538	740	1011	1506
559	771		

